

### **High Fin Tubes :**

Require easy forming materials Aluminium and its alloys allow fin heights of up to 15 mm copper of up to 10 mm. Many applications require a corrosion-resistant plain core tube. For that purpose the outer tube is rolled onto a core tube so as to provide for a firm bond with good thermal conductivity between the two tubes. For easy rolling welding or soldering into tube headers the bimetallic finned tubes may have a protruding core tube.

### **Medium High Fin Tubes**

Suitable for continuous flow heaters for the preparation of service water heating and cooling of bath solutions condensation of hydrocarbons cooling and heating of pressurized gases

### **Low Fin Tubes**

The fins are rolled out of the wall of the plain tube by use of a pass roller. Tube and fin are consisting of one piece. Application ; Water - cooled coil and condensers flooded evaporators oil preheaters water preheaters steam superheaters product coolers.

### **Corrugated Tubes**

Evaporators heat exchangers heat recovery and cooling units.

## High Fin Tubes

Max Temperature : Sk / 90 C - Bsk / 220 C  
 Outside Tube Material : Al 99.5 - 99.7  
 Inside Tube Material : Cu ( TS 380 , DIN 1786 ) - Cold Drawn Steel ASTM A 179 - ...

**$m = 3,2 \text{ mm}$**

<b>Kod</b>		d3	d4	d5	s3	h
Bsk 42/16	Sk 42/16	16	18	41	0,8 - 2	11,5
Bsk 42/18	Sk 42/18	18	20	41	0,8 - 2	10,5
Bsk 35/18	Sk 35/18	18	20	35	0,8 - 2	7,5
Bsk 35/19	Sk 35/19	19	21	43	0,8 - 2	11
Bsk 46/26	Sk 46/26	24	26	46	0,8 - 2	10

**$m = 2,2 \text{ mm}$**

Bsk 42/16	Sk 42/16	19	22	40	1 - 1,5	9
-----------	----------	----	----	----	---------	---

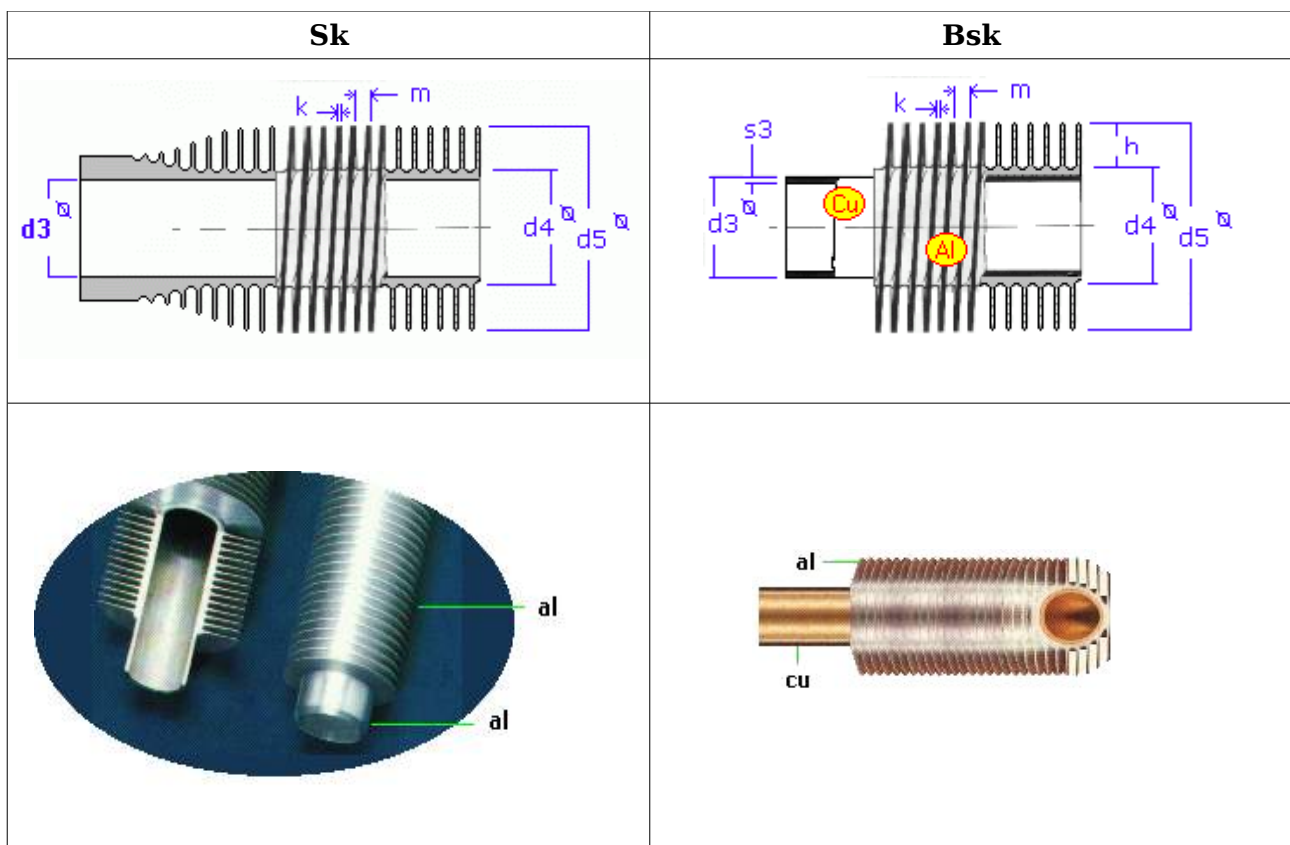

**Example**

*K 500 Turbo Kompresor air cooler with finned tubes*

## Medium High Fin Tubes

Tube Material : Al 99,5 - Al 99.7 - Cu ( TS 380 , DIN 1786 )

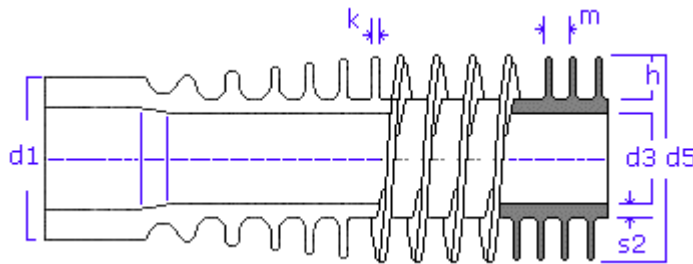
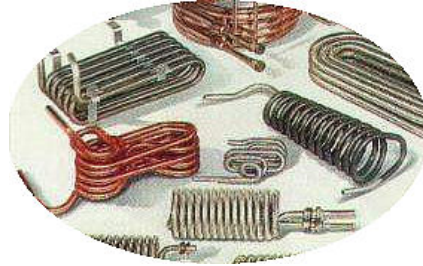

Cu - DIN 1786	mm
d1	16
d3	10,5
d5	19,5
s2	1
h	3,5
k	0,5
m	2,2

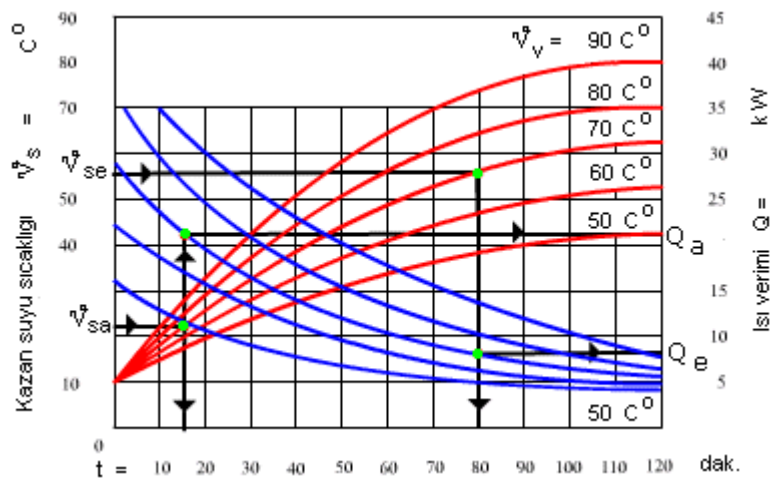

Fin Tube Performance

## Low Fin Tubes

Tube Material : Cu ( TS 380 , DIN 1786 ) - Cold Drawn Steel ASTM A 179 - ...

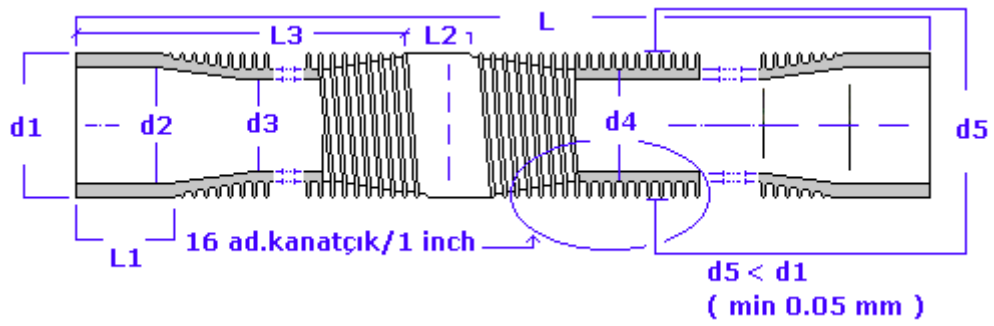

Fins/inch : 16 fin /1 inch (  $d5 < d1$  )

Kod.	d1 mm	d3 mm	d4 mm	d5 mm	m2/ m	Aa/Ai	L ( m )
Cu/dk-16	16	9,5	12,7	15,7	0,11	3,5	6 - 8
Cu/dk-19	19	12,8	15,8	18,8	0,13	3,3	6 - 8
Cu/dk-22	22,2	16	19	22	0,16	3,1	6 - 8
Cu/k-25,4	25,4	18,9	22,2	25,2	0,18	3,1	6 - 8



**Corrugated Tubes :** [www.fintube.web.tr/corrugated.html](http://www.fintube.web.tr/corrugated.html)

Corrugated tubes evaporator and liquid for experimental and theoretical results ;

Results: Flat tube film coefficient in the refrigerant (795 kcal / h C) with coefficient in the refrigerant Corrugated tubes film (1766 kcal / h C)  
Compared, curled due to a 220% increase was seen.  
The total heat transfer effects are positive is 66%.  
This significant increase in the material-saving construction provides even heat exchangers

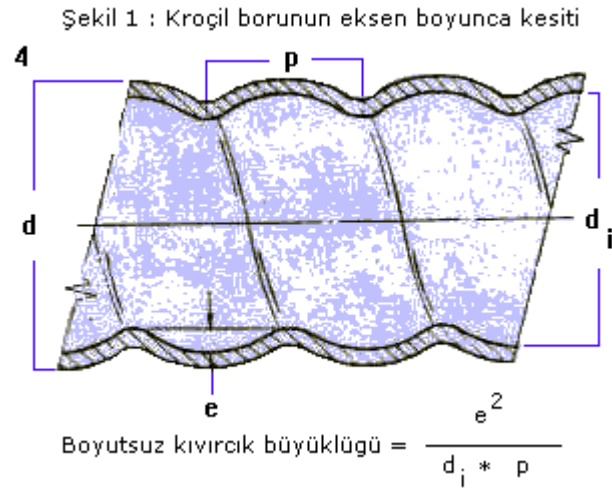

Commercial Contact

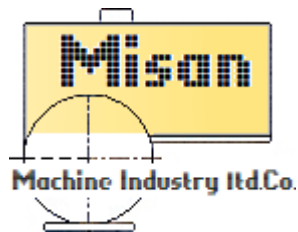

**Mr. Dr.Nusret Parildar**

Misan Makina San.Ltd.Sti.  
Organize San.Böl.Metal iş san sit.  
19 bl.No:33 34670 İkitelli - İstanbul  
Tel : 0212 5496952 - 53 - 54  
Fax :0212 54969

Technical Contact

**Mr. Tevfik Ozden**

Fintub Technician

⇒ [tevfikozden@gmail.com](mailto:tevfikozden@gmail.com)

Web : [www.fintube.web.tr](http://www.fintube.web.tr)